

NIT No. IITH/CMD/CIV/2026-27/NIT-02 (3rd Call)



भारतीय प्रौद्योगिकी संस्थान हैदराबाद
Indian Institute of Technology Hyderabad

NOTICE INVITING TENDER (NIT)

Name of the work: Supply, Installation, Testing and Commissioning of IoT-based Ultrasonic-type Digital water meters Confirming to ISO:4064-2014 for water supply lines to the additional Buildings at IIT Hyderabad, Kandi, Sangareddy (3rd Call).

17/06/2026
Executive Engineer (Civil)
IIT Hyderabad

INDIAN INSTITUTE OF TECHNOLOGY HYDERABAD

NOTICE INVITING TENDER

NIT Reference No. IITH/CMD/CIV/2026-27/NIT-02 (3rd Call)

Indian Institute of Technology Hyderabad invites on behalf of President of India online bids (**e-tender**) Item rate/~~percentage rate~~-tenders from approved and eligible *Original Equipment Manufacturers (OEM)/ Dealers /Distributors/Certified Channel Partners of the IoT Based Ultrasonic Digital Water Meters* **OR** *Civil contractors of CPWD and those of appropriate list of M.E.S., BSNL, Railway, State P.W.D. (R&B) and State Municipal/Public Health Engineering Departments/Water Boards or Water works like Hyderabad Metropolitan Water Supply & Sewerage Board (HMWSSB) etc.,* **OR** *Specialized agencies those who are having similar work experience for the below mentioned work.*

The enlistment of the contractors should be valid on the last date of submission of bid.

Copy of valid contractor's registration certificate (ROF in case of specialized agency), PAN card, GST Registration certificate & GSTIN should accompany the Technical Bid.

1.1	NIT No.:	IITH/CMD/CIV/2026-27/NIT-02 (3rd Call)
1.2	Name of Work:	<i>Supply, Installation, Testing and Commissioning of IoT-based Ultrasonic-type Digital water meters Confirming to ISO:4064-2014 for water supply lines to the additional Buildings at IIT Hyderabad, Kandi, Sangareddy (2nd Call).</i>
1.3	Estimated Cost: (given merely as a rough guide)	Rs. 8,83,382/- (PART-A: Rs. 7,51,682/- and PART-B: Rs. 1,31,700/-)
1.4	Earnest Money Deposit (EMD):	Rs. 17,700/-
1.5	Period of Completion:	<i>Part-A (Work): 100 days and Part-B (Services): 4 years, after completion of DLP period of 1 year</i>
1.6	Date of Online Publication of Tender	17/06/2026 @1500hrs
1.7	Date of Downloading of Tender	17/06/2026 @1530hrs
1.8	Last Date for Submission of Bids	29/06/2026 @1500hrs
1.9	Date and time of Opening of Technical Bids	30/06/2026 @1530hrs
1.10	Date and time of Opening of Financial Bids	01/07/2026 @1530hrs
1.11	Cost of Bid Document:	NIL

Instructions to the Bidders for Online Bid Submission

The bidders are required to submit soft copies of their bids electronically on the CPP Portal, using valid Digital Signature Certificates. The instructions given below are meant to assist the bidders in registering on the CPP Portal, prepare their bids in accordance with the requirements and submitting their bids online on the CPP Portal.

More information useful for submitting online bids on the CPP Portal may be obtained at: <https://eprocure.gov.in/eprocure/app>.

REGISTRATION

- 1) Bidders are required to enroll on the e-Procurement module of the Central Public Procurement Portal (URL: <https://eprocure.gov.in/eprocure/app>) by clicking on the link “**Online bidder Enrollment**” on the CPP Portal which is free of charge.
- 2) As part of the enrolment process, the bidders will be required to choose a unique username and assign a password for their accounts.
- 3) Bidders are advised to register their valid email address and mobile numbers as part of the registration process. These would be used for any communication from the CPP Portal.
- 4) Upon enrolment, the bidders will be required to register their valid Digital Signature Certificate (Class III Certificates with signing key usage) issued by any Certifying Authority recognized by CCA India (e.g., Sify / nCode / eMudhra etc.), with their profile.
- 5) Only one valid DSC should be registered by a bidder. Please note that the bidders are responsible to ensure that they do not lend their DSC’s to others which may lead to misuse.
- 6) Bidder then logs in to the site through the secured log-in by entering their user ID / password and the password of the DSC / e-Token.

SEARCHING FOR TENDER DOCUMENTS

- 1) There are various search options built in the CPP Portal, to facilitate bidders to search active tenders by several parameters. These parameters could include Tender ID, Organization Name, Location, Date, Value, etc. There is also an option of advanced search for tenders, wherein the bidders may combine a number of search parameters such as Organization Name, Form of Contract, Location, Date, Other keywords etc. to search for a tender published on the CPP Portal.
- 2) Once the bidders have selected the tenders they are interested in, they may download the required documents / tender schedules. These tenders can be moved to the respective ‘My Tenders’ folder. This would enable the CPP Portal to intimate the bidders through SMS / e- mail in case there is any corrigendum issued to the tender document.
- 3) The bidder should make a note of the unique Tender ID assigned to each tender, in case they want to obtain any clarification / help from the Helpdesk.

PREPARATION OF BIDS

- 1) Bidder should take into account any corrigendum published on the tender document before submitting their bids.
- 2) Please go through the tender advertisement and the tender document carefully to understand the documents required to be submitted as part of the bid. Please note the number of covers in which the bid documents have to be submitted, the number of documents - including the names and content of each of the document that need to be submitted. Any deviations from these may lead to rejection of the bid.
- 3) Bidder, in advance, should get ready the bid documents to be submitted as indicated in the tender document / schedule and generally, they can be in PDF / XLS / RAR / DWF/JPG formats. Bid documents may be scanned with 100 dpi with black and white option which helps in reducing size of the scanned document.
- 4) To avoid the time and effort required in uploading the same set of standard documents which are required to be submitted as a part of every bid, a provision of uploading such standard documents (e.g., PAN card copy, annual reports, auditor certificates etc.) has been provided to the bidders. Bidders can use “My Space” or “Other Important Documents” area available to them to upload such documents. These documents may be directly submitted from the “My Space” area while submitting a bid, and need not be uploaded again and again. This will lead to a reduction in the time required for bid submission process.

Note: *My Documents space is only a repository given to the Bidders to ease the uploading process. If Bidder has uploaded his Documents in My Documents space, this does not automatically ensure these Documents being part of Technical Bid.*

SUBMISSION OF BIDS

- 1) Bidder should log into the site well in advance for bid submission so that they can upload the bid in time i.e., on or before the bid submission time. Bidder will be responsible for any delay due to other issues.
- 2) The bidder has to digitally sign and upload the required bid documents one by one as indicated in the tender document.
- 3) Bidder has to select the payment option as “offline” to pay the tender fee / EMD as applicable and enter details of the instrument.
- 4) Bidder should prepare the EMD as per the instructions specified in the tender document. The original should be posted/couriered/given in person to the concerned official, latest by the last date and time of bid submission or as specified in the tender documents. The details of the DD/any other accepted instrument, physically sent, should tally with the details available in the scanned copy and the data entered during bid submission time. Otherwise, the uploaded bid will be rejected.
- 5) ***Tenders without valid EMD will be summarily rejected. No exemption of EMD's or process fee for MSME/NSIC registered contractors.***

- 6) Bidders are requested to note that they should necessarily submit their financial bids in the format provided and no other format is acceptable. If the price bid has been given as a standard BoQ format with the tender document, then the same is to be downloaded and to be filled by all the bidders. Bidders are required to download the BoQ file, open it and complete the white coloured (unprotected) cells with their respective financial quotes and other details (such as name of the bidder). No other cells should be changed. Once the details have been completed, the bidder should save it and submit it online, without changing the filename. If the BoQ file is found to be modified by the bidder, the bid will be rejected.
- 7) The server time (which is displayed on the bidders' dashboard) will be considered as the standard time for referencing the deadlines for submission of the bids by the bidders, opening of bids etc. The bidders should follow this time during bid submission.
- 8) All the documents being submitted by the bidders would be encrypted using PKI encryption techniques to ensure the secrecy of the data. The data entered cannot be viewed by unauthorized persons until the time of bid opening. The confidentiality of the bids is maintained using the secured Socket Layer 128-bit encryption technology. Data storage encryption of sensitive fields is done. Any bid document that is uploaded to the server is subjected to symmetric encryption using a system generated symmetric key. Further this key is subjected to asymmetric encryption using buyers/bid opener's public keys. Overall, the uploaded tender documents become readable only after the tender opening by the authorized bid openers.
- 9) The uploaded tender documents become readable only after the tender opening by the authorized bid openers.
- 10) Upon the successful and timely submission of bids (i.e., after Clicking "Freeze Bid Submission" in the portal), the portal will give a successful bid submission message & a bid summary will be displayed with the bid no. and the date & time of submission of the bid with all other relevant details.
- 11) The bid summary has to be printed and kept as an acknowledgement of the submission of the bid. This acknowledgement may be used as an entry pass for any bid opening meetings.

ASSISTANCE TO BIDDERS

- 1) Any queries relating to the tender document and the terms and conditions contained therein should be addressed to the Tender Inviting Authority for a tender or the relevant contact person indicated in the tender.
- 2) Any queries relating to the process of online bid submission or queries relating to CPP Portal in general may be directed to the 24x7 CPP Portal Helpdesk.

NOTICE INVITING TENDER

NIT Reference No. IITH/CMD/CIV/2026-27/NIT-02 (3rd Call)

1. Bidders shall produce definite proof from the appropriate authority, which shall be to the satisfaction of the competent authority, of having satisfactorily completed similar works of magnitude specified below:-

Criteria of eligibility for submission of tender documents apart from basic eligibility:

**Three similar works each of value not less than 40% of estimated cost
(OR)**

**Two similar works each of value not less than 60% of estimated cost
(OR)**

One similar work of value not less than 80% of estimated cost (rounded to nearest Rs. 10 lac) in last 7 (Seven) years ending last day of the month previous to the one in which the tenders are invited.

The value of executed works shall be brought to current costing level by enhancing the actual value of work at simple rate of 7% per annum, calculated from the date of completion to the last date of submission of tender.

“Similar Work” shall mean “Supply, Installation, Testing and Commissioning of IoT based Ultrasonic Digital Water meters to the Water Supply lines located at any levels & heights including enabling of associated Software etc., complete its Operation & Maintenance.”

The intending bidders has to submit the Similar work experience certificate furnishing with all details of the format provided at Annexure – B.

2. **The bidder should have had average annual financial turn over (gross) of Rs. 7.01 lakhs on similar works during the last three Consecutive years ending March 2025, Balance sheets should be duly audited by Chartered Accountant. Year in which no turnover is shown would also be considered for working out the average. (Scanned copy of Audited Balance Sheet to be uploaded).**
3. **Bidder has to submit tax returns filed for the firm during last three years ending 31st March 2025 (Scanned copy of returns filed to be uploaded).**
4. **Should not have incurred any loss (profit after tax should be positive) in more than two years during the last five consecutive years ending 31st March 2025, duly audited and certified by the Chartered Accountant.**
5. **Should have a Net worth certificate of Rs. 1.00 Lakh (Net worth certificate of Rs. 1.00 Lakh issued by certified Chartered Accountant with UDIN as per Format prescribed in Form B-1 of CPWD SOP 2024 at page No.214).**
6. To become eligible, the tenderer shall have to furnish an affidavit as per Form ‘J’ of the NIT.
7. Agreement shall be drawn with the successful tenderer on prescribed Form which is available in the website:
https://drive.google.com/file/d/19_LkFZ1IeQb_3BznXQtinslcLISYVdbo/view (with

up-to-date correction slips if any and additional conditions are enclosed as annexure – I) Tenderer shall quote his rates as per various terms and conditions of the said form which will form part of the agreement.

8. The time allowed for carrying out the work will be as stated at para 1 from the date of start as defined in schedule 'F' or from the first date of handing over of the site, whichever is later, in accordance with the phasing, if any, indicated in the tender documents.
9. The site for the work is available.
10. Tender documents consisting of plans, specifications, the schedule of quantities of the various classes of work to be done and the set of terms & conditions of contract to be complied with by the contractor whose tender may be accepted and other necessary documents can be seen for information at the above-mentioned website:
11. Applicants are advised to keep visiting the above-mentioned website from time to time (till the deadline for bid submission) for any updates in respect of the tender documents, if any. Failure to do so shall not absolve the applicant of his liabilities to submit the applications complete in all respects including updates thereof, if any. An incomplete application may be liable for rejection.
12. ***The contractor whose tender is accepted, will be required to furnish PG shall be 5% of the Estimated cost put to tender (ECPT) or contract amount whichever is higher, or as prescribed from time to time, to be submitted in the form as prescribed in GCC. Performance Guarantee shall remain valid for a minimum period of six months beyond the date of completion of all contractual obligations as per GCC. In case of contracts where supplementary agreement is drawn, the fresh PG shall be obtained from the contractor @ 5% of the amount of the supplementary agreement or as prescribed from time to time. The PG received against the original work shall be released as per contract conditions.*** This guarantee shall be in the form of Deposit at Call receipt of any scheduled bank/Banker's cheque of any scheduled bank/Demand Draft of any scheduled bank/Pay order of any scheduled bank or Fixed Deposit Receipts or Guarantee Bonds of any Scheduled Bank or the State Bank of India in accordance with the prescribed form. In case the contractor fails to deposit the said performance guarantee within the period as indicated in Schedule 'F'. including the extended period if any, the Earnest Money deposited by the contractor shall be forfeited automatically without any notice to the contractor.

A bid will be treated as abnormally low if the quoted bid amount is lesser than 80% of the estimated cost put to tender.

Requirement of Additional Performance Guarantee (APG): In case of abnormally low bids as defined above, the bidder shall be required to submit Additional

Performance Guarantee (APG) in addition to the standard Performance Guarantee (PG). The amount of Additional Performance Guarantee (APG) shall be equivalent to the difference between the 80% amount of ECPT and quoted amount. (e.g. if ECPT is A and quoted amount is 0.7A then the amount of APG shall be 0.8A – 0.7A).

The Additional Performance Guarantee (APG) shall be in the prescribed format of Performance Guarantee and has to be submitted within the time frame prescribed for submission of Performance Guarantee. The other terms and conditions of release etc. of APG shall be same as that of PG.

13. The description of the work is as follows:

Supply, Installation, Testing and Commissioning of IoT-based Ultrasonic-type Digital water meters Confirming to ISO:4064-2014 for water supply lines to the additional Buildings at IIT Hyderabad, Kandi, Sangareddy.

Copies of other drawing and documents pertaining to the works will be open for inspection by the tenderers at the office of above-mentioned officer.

Tenderers are advised to inspect and examine the site and its surroundings and satisfy themselves before submitting their tenders as to the nature of the ground and sub-soil (so far as is practicable), the form and nature of the site, the means of access to the site, the accommodation they may require and in general shall themselves obtain all necessary information as to risks, contingencies and other circumstances which may influence or affect their tender. A tenderer shall be deemed to have full knowledge of the site whether he inspects it or not and no extra charge consequent on any misunderstanding or otherwise shall be allowed. The tenderer shall be responsible for arranging and maintaining at his own cost all materials, tools & plants, water, electricity access, facilities for workers and all other services required for executing the work unless otherwise specifically provided for in the contract documents. Submission of a tender by a tenderer implies that he has read this notice and all other contract documents and has made himself aware of the scope and specifications of the work to be done and of conditions and rates at which stores, tools and plant, etc. will be issued to him by the Government and local conditions and other factors having a bearing on the execution of the work.

14. Tenders with any condition including that of conditional rebates shall be rejected forthwith.

15. Cost of Bid document and EMD may also be remitted to Institute's account number as per bank particulars given below:

Name of the Account Holder	: Indian Institute of Technology Hyderabad
Account Number	: 30412797764 (Current Account)
Name of the Bank	: State Bank of India
Address of the Bank	: IIT Kandi, IIT Hyderabad Campus, Kandi, Sangareddy, Telangana - 502284
Branch code	: 14182

IFSC code	: SBIN0014182
MICR code	: 502002528
SHIFT code	: SBININBB762

16. The competent authority on behalf of the President of India does not bind itself to accept the lowest or any other tender and reserves to itself the authority to reject any or all the tenders received without the assignment of any reason. All tenders in which any of the prescribed condition is not fulfilled or any condition including that of conditional rebate is put forth by the tenderer shall be summarily rejected.
17. Canvassing whether directly or indirectly, in connection with tenderers is strictly prohibited and the tenders submitted by the contractors who resort to canvassing will be liable to rejection.
18. The competent authority on behalf of President of India reserves to himself the right of accepting the whole or any part of the tender and the tenderer shall be bound to perform the same at the rate quoted.
19. The contractor shall not be permitted to tender for works if his near relative is posted a Divisional Accountant or as an officer in any capacity between the grades of Superintending Engineer and Junior Engineer (both inclusive). Any breach of this condition by the contractor would render him liable to be removed from the approved list of contractors of this Institute.
20. No Engineer of gazette rank or other Gazetted Officer employed in Engineering or Administrative duties in an Engineering Department of the Government of India is allowed to work as a contractor for a period of one year after his retirement from Government service, without the previous permission of the Government of India in writing. This contract is liable to be cancelled if either the contractor or any of his employees is found any time to be such a person who had not obtained the permission of the Government of India as aforesaid before submission of the tender or engagement in the contractor's service.
21. The tender for the works shall remain open for acceptance for a period of Ninety (90) days from the date of opening of tenders/Sixty days (60) from the date of opening of financial bid in case tenders are invited on 2/3 envelop system (strike out as the case may be) if any tenderer withdraws his tender before the said period or issue of letter of acceptance, whichever is earlier, or makes any modifications in the terms and conditions of the tender which are not acceptable to the department, then the Government shall, without prejudice to any other right or remedy, be at liberty to forfeit 50% of the said earnest money as aforesaid. Further the tenderer shall not be allowed to participate in the retendering process of the work.
- 22. (A) All taxes, Labour Cess etc., as applicable shall be borne by the contractor himself. The contractor shall quote his rates considering all such taxes including GST on works. Any recovery towards GST is notified by the competent authority,**

the same shall be effected and no claim what so ever shall be entertained by IITH. The contractor shall quote his rates accordingly.

(B) 2% as TDS amount of GST amount payable on the bills will be deducted as per the Govt. of India, Ministry of Finance, Department of Revenue notification vide No.65/39/2018-DOR, dtd: 14-09-2018 and subsequent amendment thereon.

23. GST registration certificate of the state in which the work is to be taken up, if already obtained by the bidder.

If the bidder has not obtained GST registration in the state in which the work is to be taken up or as required by GST authorities, then in such a case the bidder shall scan and upload following under taking along with other bid documents.

“If the work awarded to me, I/We shall obtain GST registration certificate of the state, in which work is to be taken up, within one month from the date of receipt of award letter or before release of any payment by IIT Hyderabad, whichever earlier, failing which I/We shall responsible for any delay in payments which will be due towards me/us on a/c of the work executed and/or for any action taken by IIT Hyderabad or GST department in this regard.”

24. Bidder has to submit Undertaking on their letter head pursuant to the Section 206AB (as applicable) of the Income Tax Act,1961 in prescribed format as enclosed at Annexure-A along with each and every bill submitted for payment.

25. This notice inviting Tender shall form a part of the contract document. The successful tenderer/contractor, on acceptance of his tender by the Accepting Authority shall within 15 days from the stipulated date of start of the work, sign the contract consisting of:-

- a) The Notice Inviting Tender, all the documents including additional conditions, specifications and drawings, if any, forming the tender as issued at the time of invitation of tender and acceptance thereof together with any correspondence leading thereto.
- b) Standard Contract form (General Conditions of Contract) as posted in the website of the Institute. The bidder is deemed to have gone through and understood the Standard Contract Form and the General Conditions of Contract.

26. Public Procurement (Preference to Make in India), Order 2017:

IIT Hyderabad shall compare all substantially responsive bids to determine the lowest valuated bid. This Institute is following and abiding with the **Public Procurement (Preference to Make in India), Order 2017, DIPP, MoCI Order No. P-45021/2/2017-B.E. II dated 15th June 2017** and its subsequent amendments. Accordingly, preference will be given to the Make in India products while evaluating the bids, however, it is the sole responsibility of the bidder(s) to specify the product quoted by them is of Make in India product along with respective documentary evidence as

stipulated in the aforesaid order in the technical bid itself.

As per the above order and its subsequent amendments “Local Content” means the amount of value added in India which shall be value of the item procured (excluding net domestic indirect taxes) minus the value of the imported content in the item (including all the custom duties) as a proportion of the total value, in percent. Accordingly, the suppliers will be classified in following categories.

Class I local Supplier – has local content minimum 50%

Class II local Supplier – has local content minimum 20%

Verification of Local Content: The Class I Local Supplier /Class II Local Supplier at the time of bidding shall be required to indicate the percentage of local content and provide **self- certification as per Annexure-C** that the items offered meet the local content requirement. The details of the location(s) at which the local value addition is made also needs to be specified.

In case of procurement in excess of Rs.10 crores, the suppliers shall be required to provide the certificate from the Statutory auditor or cost auditor of the company giving the percentage of local content.

The bidders can be debarred for a period up to two years as per Rule 151(iii) of GFR 2017, in case of false declaration.

17/06/2026
Executive Engineer (Civil)
IIT Hyderabad

(Signature of bidder)

FORM 'J'

AFFIDAVIT

I/we undertake and confirm that our firm/partnership firm has not been blacklisted by any state/Central Departments/PSUs/Autonomous bodies during the last 7 years of its operations. Further that, if such information comes to the notice of the department, then I/we shall be debarred for bidding in IIT Hyderabad in future forever. Also, if such information comes to the notice of IIT Hyderabad on any day before date of start of work, the Engineer-in-charge shall be free to cancel the agreement and to forfeit the entire amount of Earnest Money Deposit/Performance Guarantee (Scanned copy of this notarized affidavit to be uploaded at the time of submission of bid)

NOTE: Affidavit to be furnished on a 'Non-Judicial' stamp paper worth Rs.100/-

Signature of Bidder(s) or an authorized Officer of the firm with stamp

Signature of Notary with seal

Checklist of documents to be submitted along with Technical Bid

Sl. No.	Doc Ref	Description of the Document	Enclosed Yes/No	Remarks
1	As per GCC, Applicant shall submit the documents for Technical scrutiny	Copy of valid contractor's registration certificate, PAN card, GST Registration certificate & GSTIN should accompany the Technical Bid		
2	As per NIT: Registration of Contractors	<i>Original Equipment Manufacturers (OEM)/ Dealers /Distributors of the IoT Based Ultrasonic Digital Water Meters OR Civil contractors of CPWD and those of appropriate list of M.E.S., BSNL, Railway, State P.W.D. (R&B) and State Municipal/Public Health Engineering Departments/ Water Boards or Water works like Hyderabad Metropolitan Water Supply & Sewerage Board (HMWSSB) etc., OR Specialized agencies those who are having similar work experience.</i>		
3	As per NIT: Eligible Contractors	Date of Validity of Enlistment		
4	Details of Works completed during last 7 years <i>(Detailed statements to be enclosed)</i> <i>The intending bidders has to submit the Similar work experience certificate furnishing with all details of the format provided at Annexure – B</i>	Not less than 40% of estimated cost (Three similar works)		
		Not less than 60% of estimated cost (Two similar works)		
		Not less than 80% of estimated cost (One Similar work)		
5	As per the NIT (Affidavit)	The tenderer shall have to furnish an affidavit in prescribed format. (Form J)		
6	As per Para No. 1.4 of NIT	Cost of EMD		
7	As per Sl. No.23 of NIT	Undertaking for GST registration in the state in which the work is to be taken up		
8	As per Sl. No. 24 of NIT	Undertaking pursuant to Section 206AB (as applicable) of the Income		

		Tax Act, 1961 (Proforma enclosed as Annexure-A)		
9	As per Sl. No. 26 of NIT	Self-certification for Declaration of Local Content (Proforma enclosed as Annexure-C)		
10	Eligibility criteria for financial eligibility and submission of Annual Turnover related documents	Average annual financial turn over (gross) of Rs. 7.01 Lakhs on similar works (Scanned copy of Audited Balance Sheet to be uploaded)		
11	Eligibility criteria for financial eligibility and submission of Profit and Loss Statements	Should not have incurred any loss (profit after tax should be positive) in more than two years during the last five consecutive years ending 31st March 2025, duly audited and certified by the Chartered Accountant to be uploaded. (Scanned copy of returns filed to be uploaded)		
12	Eligibility criteria for financial eligibility and submission of Net Worth Certificate	Should have a Net worth certificate of Rs. 1.00 Lakh. (Net worth certificate of Rs. 1.00 Lakh issued by certified Chartered Accountant with UDIN as per Format prescribed in Form B-1 of CPWD SOP 2024 at page No.214)		
13	Details of Service Centres in Hyderabad	The intending bidder has to provide the list and details of Service Centers of proposed IoT Ultrasonic Digital Water Meters located in and around Hyderabad and have to furnish the turnaround time by the service center for attending the compliant.		
14	Technical Data Sheet of Proposed IoT based Ultrasonic Digital Water Meter	The intending Bidder has to furnish the Technical details of proposed IoT based Ultrasonic Digital Water Meters as enclosed at Annexure-2		

On Contractor/ Agency's Letter Head

Undertaking pursuant to Section 206AB (as applicable) of the Income Tax Act, 1961

To,
The Registrar
IIT Hyderabad
Kandi, Sangareddy- 502284.

Dear Sir/Madam,

Subject: Declaration confirming filing of Income Tax Return for immediate two preceding years.

I, Ms./Mrs./Mr. _____ in capacity of Authorized Signatory of _____ having PAN _____ and registered office at _____ do hereby declare that _____ has filed Income Tax Returns for immediately last 2 preceding Financial Years as mentioned below per due dates under Section 139 (1) of the Income Tax Act, 1961 ('the Act') and details of which are as given under:

Financial Year for which Income Tax Return was due as per Section 139(1)	Acknowledgement no. of ITR filed under Section 139(1)	Date of Filing
2024-25 <i>(if applicable on date of this declaration)</i>		
2023-24		
2022-23		

Further, I confirm that _____ has lined the above PAN with Aadhaar number as on this date.

I also undertake that _____ hereby indemnify **Indian Institute of Technology Hyderabad** for any loss/liability (including any Tax, interest, penalty, etc.) that may arise due to incorrect reporting of above information.

For _____

Signature: _____

Name of person:

Designation:

Place:

Date:

PROFORMA OF SCHEDULES

SCHEDULE 'A'

Schedule of quantities (Enclosed): As enclosed at Page No to.....

SCHEDULE 'B'

Schedule of materials to be issued to the contractor

Sl. No.	Description of item	Quantity	Rates in figure & words at which the material will be charged to the Contractor	Place of issue
..... NIL				

SCHEDULE 'C'

Tools and plants to be hired to the contractor

Sl. No.	Description	Hire Charges per day	Place of issue
..... NIL			

SCHEDULE 'D'

Extra schedule for specific requirements/documents for the work, if any.

--- NIL ---

SCHEDULE 'E'

Reference to General Condition of Contract.: Posted in the website of the Institute.

Name of the work : **Supply, Installation, Testing and Commissioning of IoT-based Ultrasonic - type Digital water meters Confirming to ISO:4064-2014 for water supply lines to the additional Buildings at IIT Hyderabad, Kandi, Sangareddy (3rd Call).**

Estimated cost of work : **Rs. 8,83,382/-**
[Part-A(work): Rs. 7,51,682/- and Part-B(Services): Rs. 1,31,700/-]

Earnest money : **Rs. 17,700/-**

Performance Guarantee : (1) 5.00% of the accepted tendered value or ECPT whichever is

higher of Part-A (work) & Part-B (Services), which will be returned on completion of Part-B (Services) as per ToR of GCC of the agreement.

- (2) Requirement of Additional Performance Guarantee (APG): In case of abnormally low bids i.e. if the quoted bid amount is lesser than 80% of the estimated cost put to tender, then the bidder shall be required to submit Additional Performance Guarantee (APG) in addition to the standard Performance Guarantee (PG). The amount of Additional Performance Guarantee (APG) shall be equivalent to the difference between the 80% amount of ECPT and quoted amount. (e.g. if ECPT is A and quoted amount is 0.7A then the amount of APG shall be $0.8A - 0.7A$).

Security Deposit : 2.50% of the tendered value of the Part-A work, which will be returned on completion of Part-A work as per the ToR of GCC of the agreement

SCHEDULE 'F'

GENERAL RULES AND DIRECTIONS:

Officer inviting tender: : *Executive Engineer (Civil), IITH*

Maximum percentage for quantity of items of work to be executed beyond which rates are to be determined in accordance with Clauses 12.2 & 12.3 : *See below*

Definitions:

2(v) Engineer -in- Charge : *Executive Engineer (Civil), Indian Institute of Technology, Hyderabad.*

2(viii) Accepting Authority : *Executive Engineer (Civil), Indian Institute of Technology, Hyderabad.*

2(x) Percentage on cost materials and Labour to cover all overheads and profit : *15% (Fifteen) per cent.*

2(xi) Standard Schedule of Rate : *CPWD, Delhi Schedule of Rates (DSR) 2023 Civil / Electrical (2025), with up-to-date correction slips.*

Standard Contract Form : *IITH General Conditions of Contract*

Clause 1

i) Time allowed for submission of Performance Guarantee, Programme Chart (Time and Progress) and applicable licenses, registration with EPFO, ESIC and BOCW Welfare Board or proof of applying thereof from the date of issue of letter of acceptance, in days : *15 (Fifteen) Days*

ii) Maximum allowable extension beyond the period provided in(i) above : *7 (Seven) Days*

Clause 1A

Whether Clause 1A is applicable : *Yes*

Clause 2

Authority for fixing Compensation under Clause 2 : *Executive Engineer (Civil), Indian Institute of Technology, Hyderabad*

Clause 3(VII): If the contractor had secured the contract with Government as a result of wrong tendering or other non-bonafide methods of competitive tendering or commits breach of Integrity Agreement-will be made ineligible.

Clause 5:

Number of days from the date of issue of letter of acceptance for reckoning date of start : *15 Days or date of issue of LOC whichever is later*

Milestones : *Not Applicable*

Time allowed for execution of work : **(a) Part-A(work): 100 Days**
(b) Part-B(services): 4years, after completion of 1year DLP period.

Authority to give fair and reasonable Extension of time for completion of work (hindrance register) : *Executive Engineer (Civil)*

Clause 6:- Measurement Book : (i) *For works having estimated cost more than Rs. 15 Lakh – Clause 6*
Clause applicable, 6 : (ii) *For works having estimated cost Rs. 15 Lakh or less – Contractor’s option of Clause 6 or to be exercised at the time of Tender Submission*

Clause 7:

Gross work to be done together with net payment /adjustment of advances for material collected, if any, since the last such payment for being eligible to interim payment : Rs. 5 Lakhs/-

Clause 7A: : *Yes.*
Whether Clause 7A is applicable : *No running account bill shall be paid for the work till the applicable labour licenses, registration with EPFO, ESIC and BOCW Welfare Board, whatever applicable are submitted by the contractor to the Engineer-in-charge.*

Clause 10A:

List of testing equipment to be provided by the contractor at site lab : *As given in additional specifications*

Clause 10B (ii)- Mobilization advance:

Whether Clause 10 B (ii) shall be applicable : *Not Applicable*

Clause 10C:

Component of labour expressed as percent of value of work : *25%*

Clause 11:

Specification to be followed for execution of work :

CIVIL WORKS

CPWD DSR Items:

CPWD Specifications 2019 Vol. I & II, with up-to-date correction slips,

For MORTH Items

MORTH Specifications 2013, with up-to-date correction slips.

For ELECTRICAL WORKS

i) CPWD DSR Items:

CPWD General Specifications
Part I Internal 2023
Part II External 2023
Part III Lifts & Escalators 2003
Part IV Substations 2013
Part V Wet Riser
Sprinkler System 2020
Part VI Fire Detection and Alarm System 2018
Part VII DG Sets 2013
Part VIII: Gas based fire extinguisher systems 2013
all with up-to-date Corrections Slips.

For all Market Rate Items:

Particular Specifications

Clause 12:

12.2 & 12.3: Deviation limit beyond which Clause 12.2 & 12.3 shall apply for building work :

100% (as per CPWD circular No. DG/SOP/16 Dt: 15.02.2021)

12.5 : Deviation Limit beyond which clauses 12.2 & 12.3 shall apply for foundation work :

100% (One hundred per cent)

Clause 14:

Whether Clause 14 is applicable :

Yes.

Clause 16

Competent Authority for deciding reduced rates. :

Superintending Engineer, IIT Hyderabad up to 5% of tendered

amount, beyond which, Director, IITH.

Clause 18:

List of mandatory machinery, tools & plants to be deployed by the contractor at site

: As required for the work.

Clause 25:

(i) Settlement of disputes by Conciliation and Arbitration:

- Conciliator Dean (Planning)
- Authority to appoint arbitrator Director, IIT Hyderabad
- Place of Arbitration Hyderabad
- Venue of Arbitration IIT Hyderabad
- Type of Arbitration Tribunal Sole Arbitrator

Note: Provisions of Arbitration and Conciliation Act 1996 with latest amendments in force shall be applicable.

Clause 32:

Requirement of Technical Representative(s) and Recovery Rate

Sl. No	Minimum Qualification of Technical Representative	Discipline	Designation (Technical Representative)	Minimum Experience (years)	Number	Rate at which recovery shall be made from the contractor in the event of not fulfilling provision of Clause 36(i) (INR) / Month / Each	
						Figures	Words
1	Engineering Graduate	Civil/ Electrical	Sr. Technical Representative	10	NIL	50,000/-	Rupees Fifty Thousand Only
2	Diploma Engineer	Civil/ Mechanical	Technical Representative (Construction Manager)	5	1	30,000/-	Rupees Thirty Thousand Only
3	Diploma Engineer	Electrical/ Mechanical	Technical Representative (Construction Manager)	5	NIL	30,000/-	Rupees Thirty Thousand Only

Note: Assistant Engineers retired from government services that are holding diploma will be treated at par with graduate engineers.

Clause 38

(i): Schedule/statement for determining theoretical quantity of cement & bitumen on the basis of Delhi Schedule of Rates

: DSR – 2023 for Civil and 2025 for Electrical published by CPWD

(ii): Variations permissible on theoretical quantities:

- (a) Cement : 2% plus/minus
- (b) Bitumen All Works : 2.5% plus only & nil on minus side.
- (c) Steel Reinforcement and structural steel sections for each diameter, section and category : 2% plus/minus
- (d) All other materials Nil

RECOVERY RATES FOR QUANTITIES BEYOND PERMISSIBLE VARIATION

Sl. No.	Description of Item	Rates in figures and words at which recovery shall be made from the Contractor	
		Excess beyond permissible variation	Less use beyond permissible variation
1.	Cement	Nil	6,800+10% per MT
2.	Steel Reinforcement	Nil	63,000+10% per MT
3.	Structural Steel Sections	Nil	69,000+10% per MT

Special Conditions of Contract

SPECIAL CONDITIONS:

1. Before tendering, the contractor shall inspect the site of work and shall fully acquaint himself about the conditions prevailing at site, availability of materials, availability of land and suitable location for construction of godowns, stores and camp, transport facilities, the extent of lead and lifts involved in the work (over the entire duration of contract) including local conditions, as required for satisfactory execution of the work and nothing extra whatsoever shall be paid on this account.
2. The contractor shall at his own expense and risk arrange land for accommodation of labour, setting up of office, the storage of materials, erection of temporary work-shops, and construction of approach roads to the site of the work including land required for carrying out of all jobs connected with the completion of the work. In any case. IIT Hyderabad (Institute) shall not permit setting up of labour camps within its premises. If during construction it becomes necessary to remove or shift the stored materials shed workshop, access roads, etc. to facilitate execution of any other work by any other agency, the contractor shall do as directed by the Engineer-in-charge and no claim whatsoever, shall be entertained on this account.
3. It shall be deemed that the contractor shall have satisfied himself as to the nature and location of the work, transport facilities, availability of land for setting up of camp etc. The department will bear no responsibility for lack of such knowledge and the consequences thereof.
4. The contractor shall have to make approaches to the site, if so required and keep them in good condition for transportation of labour and materials as well as inspection of works by the Engineer-in-charge. Nothing extra shall be paid on this account.
5. The contractor shall be responsible for the true and proper setting out of the work in coordination with the Engineer-in-charge or his authorized representatives and for the correctness of the positions, levels, dimensions and alignments of all parts of the structure and for the provisions of all necessary instruments appliances and labour in connection therewith. If at any time, during the progress of work, any error appears or arises in the position, levels, dimensions or alignment of any part of the work, the contractor on being asked to do so by the Engineer-in-charge, shall rectify such error to the entire satisfaction of Engineer-in-charge. The checking by the Engineer-in-charge or his authorized representative shall not relieve the contractor of his responsibility for the correctness of any setting out of any line or level. The contractor shall carefully protect and preserve all bench marks pegs and pillars provided for the setting out of works.
6. All setting out activities concerning establishment of benchmarks, theodolite stations centre line pillars etc. including all materials, tools, plants, equipment, theodolite and all other instruments, labour etc. required for performing all the functions necessary and ancillary thereto at the commencement of the work, during the progress of the work and till the completion of the work shall be carried out by the contractor and nothing extra shall be paid on this account.
7. The contractor shall at his own cost submit samples of all materials sufficiently in

advance and obtain approval of the Engineer-in-charge. Subsequently, the materials to be used in the actual execution of the work shall strictly conform to the quality of samples approved by the Engineer-in-charge and nothing extra shall be paid on this account. The acceptance of any sample or material on inspection shall not be a bar to its subsequent rejection, if found defective.

- 8.** The contractor shall at his cost, make all arrangements and shall provide necessary facilities as the Engineer-in-charge may require for collecting, preparing, packing forwarding and transportation of the required number of samples for tests for analysis at such time and to such places as directed by the Engineer-in-charge, and bear all charges and cost of testing unless specifically provided for otherwise elsewhere in the contract or specifications. The cost of tests shall be borne by the contractor/Institute in the manner indicated below (except for water):

 - a) By the contractor, if the results show that the material does not conform to relevant specifications and BIS codes or any other relevant code for which conformity test is carried out.
 - b) By the Institute, if the results show that the material conforms to relevant specifications and BIS codes or any other relevant code for which conformity test is carried out.
- 9.** The necessary tests shall be conducted in the laboratory approved by the Engineer-in-charge. The samples for carrying out all or any of the tests shall be collected by the Engineer-in-charge or on his behalf by any other officer of the Institute. The contractor or his authorized representative shall associate himself in collection, preparation, packing and forwarding of such samples for the prescribed tests and analysis. In case he or his authorized representative is not present or does not associate him, the results of such tests and consequences thereon shall be binding on the contractor.
- 10.** Materials used on work without prior inspection and testing (where testing is necessary) and without approval of Engineer-in-charge are liable to be considered unauthorized, defective and not acceptable. The Engineer-in-charge shall have full powers to require removal of any or all of the materials brought to site by contractor which are not in accordance with the contract, Specifications or do not conform in character or quality to the samples approved by the Engineer-in-charge. In case of default on the part of the contractor in removing rejected materials, the Engineer-in-charge shall be at liberty to have them removed at the risk and cost of the contractor.
- 11.** The contractor shall make his own arrangement for the water required for execution of work and get the water tested at his own cost with regard to its suitability for use in the works and get written approval from the Engineer-in-charge before he proceeds with the use of same for execution of work. Nothing extra shall be paid to the contractor on this account.
- 12.** The work shall be carried out in such a manner so as not to interfere/or effect or disturb other works being executed by other agencies, if any.

- 13.** Any damages done by the contractor to any existing work or work being executed by other agencies shall be made good by him at his own cost.
- 14.** The work shall be carried out in the manner complying in all respects with the requirement of relevant rules and regulations of the local bodies under the jurisdiction of which the work is to be executed and nothing extra shall be paid on this account.
- 15.** For completing the work in time, the contractor might be required to work in two or more shifts and no claims whatsoever shall be entertained on this account, notwithstanding the Fact that the contractor will have to pay to the labourers and other staff engaged directly or indirectly on the work according to the provisions of the labour regulations and the agreement entered upon and/or extra amount for any other reasons,
- 16.** The contractor will have to make his own 'arrangement for obtaining electric connection from the state electricity board and make necessary payments directly to the department concerned and/or install generators at the site of work, if required and nothing extra whatsoever will be payable on this account.
- 17.** The drawings for the work attached in the document relating to this contract and all other drawings that will be issued by the Engineer-in-charge during the execution of work shall at all times be properly correlated before executing any work and no claim whatsoever shall be entertained on this account.
- 18.** The contractor shall maintain in good condition all work executed till the completion of the entire work entrusted to the contractor under this contract and nothing extra shall be paid on this account.
- 19.** No payment will be made to the contractor for damage caused by rain, floods and other natural calamities whatsoever during the execution of the works and any damage to the work on this account shall have to be made good by the contractor at his own cost and nothing whatsoever' shall be paid on this account.
- 20.** The item rates or percentage rates for all items of work, unless clearly specified otherwise, shall include the cost of all labour materials, de-watering and other inputs involved in the execution of the items.
- 21.** Unless otherwise provided in the schedule of quantities or CPWD Specifications the percentage rates tendered by the contractor shall be all-inclusive and shall apply to all heights, depths, leads and lifts.
- 22.** No claim whatsoever for idle labour, additional establishments, costs of hire and labour charges for tools and plants etc. would be entertained under any circumstances.
- 23.** For the safety of all labour directly or indirectly employed in the work for the performance of the contractor's part of this agreement, the contractors shall, in

addition to the provisions of Safety code and directions of the Engineer-in-charge make all arrangements to provide facility as per the provisions of Indian Standard Specifications (Codes) listed below and nothing extra shall be paid on this account.

- (a) IS 3696 Part I Safety Code for scaffolds and ladders
- (b) IS 3696 Part II Safety Code for scaffolds and ladders Part II ladders
- (c) IS 764 Safety Code for excavation work
- (d) IS 4081 Safety Code for Blasting and Drilling operations,
- (e) IS4138 Safety Code for working in compressed air.
- (f) IS 7293 Safety Code for working with construction machinery
- (g) IS 7969 Safety Code for storage and handling of building materials
- (h) IS 5216:1982 code of safety procedures and practices in electrical works

24. The contractor shall take all precautions to avoid all accidents by exhibiting necessary caution boards and by providing red flags, red lights and barriers. The contractor shall be responsible for any accident at the site of work and consequences thereof.

25. In case of Specifications the following hierarchy will be followed:

- (1) Nomenclature of the item.
- (2) Additional Specifications, particular Specifications, special / additional conditions if any as defined in the contract documents.
- (3) Drawings
- (4) CPWD Specifications,
- (5) BIS Specifications (Latest version) if CPWD Specifications not available.
- (6) Manufacturers Specifications if BIS Specifications not available.
- (7) Sound Engineering Practices Standard Textbooks.
- (8) If none of the above is available decision of Engineer-in-Charge will be final.

26. All Stone aggregates, sand, stone dust, etc shall be obtained only from the quarry or other source approved by the Engineer in charge before they are actually procured and used in the work. The percentage rate for the items mentioned in the schedule of quantities includes all charges and nothing-extra payable on any account.

27. Labour Welfare Cess @ 1% shall be deducted at source from the bills of Gross value (which includes the cost of stipulated materials) of the work done and Government

shall not entertain any claim whatsoever in this respect in this contract.

28. The ESI and EPF Contribution on the part of the employer in respect of the contract shall be paid by the contractor. This contribution on the part of the employer paid by the contractor shall be reimbursed by the Engineer-in- Charge to the contractor on actual basis. The applicable and eligible amount of EPF and ESI shall be reimbursed preferably within 7 days but not later than 30 days of submission of documentary proof of payment provided same are in order.
29. No Running Account Bill shall be paid for the work till the applicable labour license, registration with EPFO, ESIC and BOCW Welfare Board, whatever applicable are submitted by the contractor to the Engineer-in-charge.
30. The contractor shall obtain a valid licence under the contract labour (R A) Act, 1970 and the contract labour (Regulation and Abolition) Central Rules, 1971 before the commencement of the work, and continue to have a valid licence until the completion of the work. The contractor shall also comply with provision of the Inter-state Migrant Women (Regulation of Employment and conditions of service) Act 1979.
31. ***The tenderer (non-manufacturer) shall submit Memorandum of Understanding (MoU) / Manufacturer's Authorisation Form (MAF) / Dealership Certificate / Certified Channel Partner for the subject work from original equipment manufacturer (OR) If the tenderer is a Manufacturer of ultrasonic water meters, then the manufacturer shall submit the manufacturer unit registration certificate.***
32. ***The intending bidders shall have their proposed Digital Water Meter Manufacturer's Service Center in and around 150 Kms from the IIT Hyderabad, Kandi, Sangareddy, Telangana and bidders shall have to provide the DETAILS OF SERVICE CENTERS in Hyderabad and turnaround time for servicing.***
33. ***If turnaround service time exceeds 2 working days (i.e. 48 hours), then the fine will be imposed Rs.500/- Per day per meter. Overall Contract Period, the total fine shall not be exceeded or limited to 10% of the total Annual Maintenance Cost (AMC) of the contract amount.***
34. ***For the 25 mm and above dia Ultrasonic meters, the Contractor shall be submitted FCRI (Fluid Control Research Institute), Palakkad, Kerala/ MID (Measuring Instruments Directive) Certificate including IP68 Certificate and other mandatory reports, related documents etc., along with the supply of meters.***
35. ***The successful bidder shall be produced MTCs of Ultrasonic Digital water meters (with dual GMS-SIMs), which obtained either from FCRI (Fluid Control Research Institute), Palakkad, Kerala (OR) from NABL accredited labs.***
36. ***The Contract agreement with successful bidders shall be executed for Total work (i.e. Part-A Work and Part-B Services). Part-A work agreement part shall be come in to force from commencement of work to till the completion of work including its Defect Liability Period (DLP) of 1 year AND Part-B Services agreement part***

shall be come in to force after completion of Defect Liability Period of Part-A work to till the completion of 4 years of AMC Period as per the terms and conditions of Contract Agreement.

- 37. The Performance Guarantee shall be deposited 5.00% of the accepted tendered value or Estimated cost put to tender whichever is higher of Part-A (work) & Part-B (Services), which will be returned on completion of Part-B (Services) as per ToR of GCC of the agreement.**
- 38. The Security Deposit shall be deposited 2.50% of the tendered value of the Part-A work, which will be returned on completion of Part-A work as per the ToR of GCC of the agreement.**
- 39. Before quoting the bids, the intending bidders have to visit the IIT Hyderabad as the proposed ultrasonic digital water meters have to synchronize with the existing digital water meters & its operations and further monitoring them uniformly.**

Smart Water Accounting System (SWAS) for IIT Hyderabad campus

Terms of Reference (TOR)

Scope of work

The supplier shall be required to provide all the following material / services for implementation of the Smart Water Accounting System (SWAS). The scope of work shall include

1. Complete Supply, Installation and Commissioning of 15 Nos of Inline Smart Ultrasonic Water Flow Meters with inbuilt telemetry unit including arrangements for installation on the identified tubewells. Initial Water survey has to be done by the supplier and the quantities shall be finalized based on the results of the same.
2. The meters shall transmit the real-time water flow data using cellular 4G /5G communication to a secure cloud. The cloud service provider shall be empanelled with MeitY.
3. The meter shall have provision for dual-SIM to overcome connectivity challenges from 1 network operator.
4. The SIM cards shall be supplied by the bidder based on the available network at the respective site. Data transmission charges shall be borne by the bidder for the entire project period including the O&M period.
5. The bidder shall provide operation and maintenance services for Four (4) years from the date of commissioning of products.
6. The data shall be transmitted every 8 hours
7. All accessories required for the installation like flanges, gaskets, nuts and bolts shall be supplied by the bidder.
8. The bidder shall take care of all necessary works like cutting, welding and installation of flow meter as per the installation instructions provided in the technical specification.
9. The pipes available are a mix of GI & PVC materials. Suitable installation method shall be adopted as per the site location.
10. The U bend structure which will be installed shall be of GI/PVC material with firm support from ground in the form of concrete platform. The support shall be firm and should be capable of firmly holding the meter even in strong wind.
11. Although all accessories and fixtures required for installation of the equipment & their specifications have been specified in technical specifications, the bidder shall ensure the satisfactory performance & functioning of Smart Ultrasonic Water Flow Meters complete, for this if any accessory or items are required that shall be provided by the bidder.
12. The detailed product and software requirements are mentioned below.
13. The bidder may be called for presentation/demonstration of the product as part of technical evaluation during the evaluation process.

Technical specifications of Tamper Proof IoT Based Ultrasonic Digital Water Flow Meters with Telemetry:

Metering Technology	Ultrasonic
Meter size	DN20 up to DN300 - To be finalized in Water Survey
Communication	Inbuilt dual SIM based 4G/5G with fallback on 2G.
Power Source	<p>The meter and telemetry shall be operated using non-rechargeable Lithium batteries with minimum 5 years life with 1 transmission per day.</p> <p>(The bidder may have to justify the life of the battery by disclosing/demonstrating the power consumption during different modes compared to the battery full capacity during technical evaluation)</p>
Sealing	The meter and telemetry system shall have proper mechanical and electronic sealing arrangement.
Certification	ISO 4064: 2014
Ingress Protection	Meter along with the telemetry system should be housed and sealed in a single box and shall be IP68 compliant.
Accuracy	Class 2, T50, as per ISO 4064:2014
Performance Certificate	The meter manufacturer shall submit the performance test certificate as per ISO4064 from FCRI along with the bid.
Calibration Lab	The meter manufacturer must possess a NABL-accredited permanent facility dedicated to the calibration and testing of Ultrasonic Flowmeters, with a flow range spanning from 2.5 m ³ /hr to 125 m ³ /hr. The Calibration and Measurement Capability (CMC) of the facility should be less than 0.65% across the entire flow range. A valid certification must be attached with the bid.
Parameters to monitor	<p>The meter should transmit the following parameters to a secure cloud once / thrice in a day</p> <ol style="list-style-type: none">1. Timestamp2. Cumulative flow volume3. Cumulative pump working hours4. Instantaneous flow rate at the time of transmission5. Pump ON/OFF timestamp6. Cumulative flow volume at every ON & OFF

	event
Cloud	The Communication / telemetry data should be directly captured in a secure cloud. The cloud service provider should be empanelled with MeitY.
Data logging & transmission frequency	Every 24 hours / 8 hours by default. It should be configurable over the air.
Data Storage	The meter shall store the data internally in the meter for minimum 1 year
Battery Life	The Lithium battery shall run for a minimum of 5 years with 1 transmission per day. The battery shall be replaceable on field without any data loss.
Data Management Software	The bidder shall acquire the data in the secured cloud and shall provide a web dashboard and mobile application to view and download data from the meters. The cloud service provider shall be empanelled by MeitY. Detailed software requirements are mentioned below.
Communication protocol	The device shall use light weight MQTTS protocol to establish connection with the server so that data can be transferred securely
Communication security	The communication from the device and the cloud shall be secured with a minimum TLS1.2 standard to ensure data integrity and privacy.
Integration with other dashboards	The bidder shall provide web APIs to integrate the flow meter data with any other dashboard as desired by the purchaser.
Installation of Meter	
Location	The meter shall be installed at the bore-well pump discharge line as shown in Figure. 1
Other requirements	
Material of construction	The body of the meter shall be brass/bronze/cast iron/engineering plastic
Meter indicator	The meter shall display the following parameters on LCD <ul style="list-style-type: none"> 1) Instantaneous flow rate 2) Cumulative flow volume 3) Flow direction

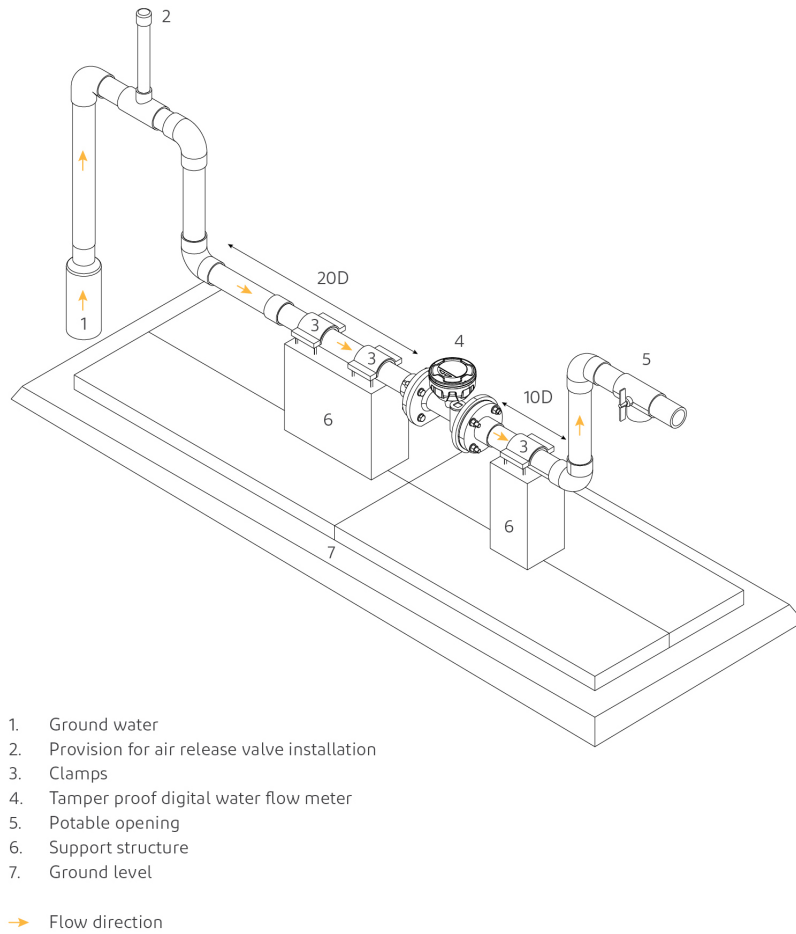

Figure 1
 Installation position of tamper proof digital flow meter with telemetry (Only for groundwater abstraction, if any)

Software requirements

Cloud environment	The Communication/telemetry data should be directly captured in a secure cloud. The cloud service provider should be empanelled with MeitY.
User logins	Logins shall be provided from ground user level to higher management level grouping the devices as per the requirement of the User (or) Institute. The software shall have the provision for device grouping and hierarchy mapping as given.
Reporting	The software shall provide detailed reports downloadable from the application and also sent through automated email. The following minimum reports shall be available on the

	<p>software.</p> <ol style="list-style-type: none"> 1. Daily extraction report 2. Monthly extraction report 3. Division/cluster wise usage report
Data visualization	<p>The software shall have inbuilt data analytics with visualization for minimum following features</p> <ol style="list-style-type: none"> 1. Graph on daily water extraction as per device/cluster 2. Graph on monthly water extraction as per device/cluster 3. Device related static information including calibration certificate, installation date, calibration due date,
Alerts and Notifications	<p>The system shall be able to generate the following minimum alerts via email/SMS/WhatsApp at device and cluster level as per the requirement</p> <ol style="list-style-type: none"> 1. Daily water extraction 2. Monthly water extraction 3. Deviation from assigned limits 4. Deviation from pumping schedule 5. Low yield from the well
Device management	<p>The software shall display device details along with device performance such as</p> <ol style="list-style-type: none"> 1. Battery status 2. Network status
Data security	<p>Software shall be hosted on a secured cloud which ensures both encryption at rest and encryption in transit.</p>
Advanced analytics	<p>The software shall have the capability to generate on-demand advanced analytics and customized reports on the flow meter time series data.</p> <p>The advanced reports include but not limited to</p> <ol style="list-style-type: none"> 1. Borewell health indices 2. Borewell usage patterns 3. Predictive maintenance of devices

ANNEXURE – B

CLIENT's CERTIFICATE REG. PERFORMANCE OF CONTRACTOR

Name & address of the Client.....

Details of works executed by Shri/ M/s.

1. Name of work with brief particulars	
2. Agreement No. and date	
3. Estimated Cost	
4. Agreement amount	
5. Date of commencement of work	
6. Stipulated date of completion	
7. Actual date of completion	
8. Details of compensation levied for delayed completion, if any	
(a) Whether case of levy of compensation for delay has been decided or not	Yes/No
(b) If decided, amount of compensation levied for delayed completion, if any	
9. Amount of reduced rate items, if any	
10. Performance Report	
a) Quality of Work	Outstanding / Very Good / Good / Poor
b) Financial Soundness	Outstanding / Very Good / Good / Poor
c) Technical Proficiency	Outstanding / Very Good / Good / Poor
d) Resourcefulness	Outstanding / Very Good / Good / Poor
e) General behavior	Outstanding / Very Good / Good / Poor

Dated:

Executive Engineer or Equivalent

Declaration for Local Content

(To be given on Company Letter Head - For tender value below Rs.10 Crores)

(To be given by Statutory Auditor/Cost Auditor/Cost Accountant/CA for tender value above Rs.10 Crores)

Date: _____

**To,
The Director,
Indian Institute of Technology Hyderabad,
Kandi, Sangareddy 502284.**

Sub: Declaration of Local content

Tender Reference No: _____

Name of Tender / Work: _____

1. Country of Origin of Goods being offered: _____
2. We hereby declare that items offered has _____% local content.
3. Details of location at which local value addition will be made / made: (Complete address to be mentioned) _____

“Local Content” means the amount of value added in India which shall, be the total value of the item being offered minus the value of the imported content in the item (including all customs duties) as a proportion of the total value, in percent.

*“*False declaration will be in breach of Code of Integrity under Rule 175(1)(i)(h) of the General Financial Rules for which a bidder or its successors can be debarred for up to two years as per Rule 151 (iii) of the General Financial Rules along with such other actions as may be permissible under law.”*

Yours Faithfully,

(Signature of the Bidder, with Official Seal)

Annexure- 2

TECHNICAL DATA SHEET

DATASHEET TO BE FILLED BY THE BIDDER:

ULTRASONIC DIGITAL WATER: GENERAL TECHNICAL DATA SHEET

The bidder has to fill following data sheets, and to be submitted along with the bid submission. In case if bidder is offering an alternate make for the same item, then a separate data sheet is to be filled for each make. It may be noted Data sheet submitted by the bidder for measure items shall only be for information and understanding of the tender. However, finalization of all items shall be carried out after the award of work to the successful bidder based on detailed specifications, quality plan, etc. On that basis, the Bill of Materials (BOM) shall be finalized.

The bidders / certified channel partners should furnish the following data sheet in consultation with the (OEM) and should provide the authentication certificate from the Manufacturer.

S.no	Parameters	Data / Technical Details	Remarks
1.	Meter Technology		
2.	Material of Construction		
3.	Installation of Smart meters		
4.	Manufacturer / Vendor		
5.	Established		
6.	Address		
7.	Model / Make		
8.	Certification		
9.	Type of Communication		
10.	Accuracy		
11.	Data Management Licensed Software		
12.	Power Source		
13.	Sealing		
14.	Ingress protection		
15.	Parameters to Monitor		
16.	Performance Certificate		
17.	Calibration Certificate		
18.	Cloud		
19.	Data Login and Transmission Frequency		
20.	Data Storage		
21.	Data Security		
22.	Life of Battery		

23.	Type of Battery		
24.	Communication Protocol		
25.	Communication Security		
26.	Integration with another dashboard		
27.	Meter Indicator		
28.	Device Management		
29.	Alerts and Notifications		
30.	No of User Logins		
31.	Reporting Data		
32.	Data Visualization (hourly, daily, weekly, monthly, and yearly)		
33.	Warranty, Annual manufacturing capacity of Smart meters		
34.	Is Complying with Certification of BIS Code: 4064-2014?		

Additional Conditions of Contract

Additional Conditions:

1. The contractor shall make his own arrangements for obtaining electric connections if required and make necessary payments directly to the department concerned.
2. Other agencies doing works related with this project will also simultaneously execute the works and the contractor shall afford necessary facilities for the same. The contractor shall leave such necessary holes, openings etc. for laying/burying in the work of pipes, cables, conduits, clamps, boxes and hooks for fan clamps etc. as may be required for other agencies. Conduits for electrical wiring/cables will be laid in a way that they leave enough space for concreting and do not adversely affect the structural members. Nothing extra over the agreement rates shall be paid for the same.
3. Some restrictions may be imposed by the Institutes security staff etc., on the working and for movement of labour, materials etc. The contractor shall be bound to follow all such restrictions/instructions and nothing extra shall be payable on this account.
4. The building work will be carried out in the manner complying in all respects with the requirements of relevant byelaws of the local body under the jurisdiction of which the work is to be executed or as directed by the Engineer-in-Charge and nothing extra will be paid on this account.
5. The work of water supply, Internal Sanitary Installations and drainage work etc., shall be carried out as per local Municipal Corporation or such local body bye-laws and the contractor shall produce necessary completion certificate from such authorities after completion of the work.
6. Water tanks, taps sanitary, water supply and drainage pipes, fittings and accessories should conform to byelaws and specifications of the Municipal Body/Corporation where CPWD specifications are not available. The contractor should engage licenced plumbers for the work and get the materials (fixtures/fittings) tested by the Municipal Body/Corporation authorities wherever required at his own cost.
7. The contractor shall comply with proper and legal orders and directions of the local or public authority or municipality and abide by their rules and regulations and pay all fees and charge, which he may be liable.
8. The contractor shall give a performance test of the entire installation(s) as per standard Specifications before the work is finally accepted and nothing extra whatsoever shall be payable to the contractor for the test.
9. Any cement slurry added over base surface (or) for continuation of concreting for better bond is deemed to have been in built in the items and nothing extra shall be payable (or) extra cement considered in consumption on this account.
10. **Applicable for Works Costing more than Rs 25 Lakh**

The Contractor shall furnish his proposed methodology and programme of construction in comprehensive manner of executing and completing the work within the stipulated period and also for achieving the milestones simultaneously within the specified periods in schedule F within 7 days of award of tender. The programme shall consist of the various components for each part of the work stipulated to be completed and a bar chart may be appended in this connection.

11. The contractor shall take instructions from the Engineer-in-Charge for stacking of materials in any place. No excavated earth or building material shall be stacked on areas where other buildings, roads, services compound walls are to be constructed.
12. As a policy of the Institute, huts for labour are not permitted at the site of work by the contractors. The contractors are required to provide such accommodation outside the premises of the Institute and nothing extra shall be paid on this account.
13. Royalty at the prevalent rates shall have to be paid by the contractor on all the boulders, metals, shingle sand and bajri etc., collected by him for the execution of the work direct to the Revenue authority or authorized agent of the State Government concerned or Central Government.
14. The Percentage Rate for Centering shuttering includes cost of centering the rate of RCC works include cost of concreting in sloped roof/ chajjas / beams and no extra rate shall be payable on any account. Single stone slab only should be used in treads and risers of staircase steps etc. Payment shall be made in respect of items. No extra rate shall be payable on this account.
15. The Contractor should construct proper mortar bands of lean mix with adequate depth smaller size over the curved roof for flooding with water proper curing. In case of Arches, wet gunny bags shall be used for a period of two weeks.
16. Samples of all materials like UPVC Pipes, fittings, tiles etc., shall be got approved in advance before placing order for them. Similarly, samples of all works shall be prepared in advance and got approved from the Engineer-in-Charge before taking up the work
17. The contractor shall procure all the materials in advance so that there is sufficient time for testing and approving the material and clearance of the same before use in work.
18. The Percentage rate for skirting, dados includes cost of chasing of Brick walls to the required thickness wherever required in order to accommodate required thickness of base cement mortar and nothing extra is payable.
19. The Percentage rate for the different flooring items under flooring sub head, includes the cost of extra cement mortar required to be laid for making the finished floor level at par with the kota stone flooring at all floors and at all levels, and nothing extra shall be payable on any account.
20. No payment shall be made for preparing the existing surface like flooring, masonry etc.

for hacking, cleaning to receive new work.

21. No payment shall be made for extra for scaffolding required for external works at all levels.

22. Applicable for Works costing more than Rs 50 Lakh

23. **Reports to be submitted by Contractor**

- (i) The contractor shall submit monthly progress report of the work in a computerized form. The progress report shall contain the following, apart from whatever else may be required as specified: i) Project information, giving the broad features of the contract.
- (ii) Introduction, giving a brief scope of the work under the contract, and the broad structural or other details.
- (iii) Construction schedule of the various components of the work through a bar chart for the next 2 quarters (or as may be specified), showing the milestones, targeted tasks and up to date progress.
- (iv) Progress chart of the various components of that are planned and achieved, for the month as well as cumulative up to the month, with reasons for deviations, if any, in a tabular format.
- (v) Plant and machinery statement, indicating those deployed in the work, and their working along with their designations.
- (vi) Manpower statement, indicating individually the names of all the staff deployed in the work, along with their designations.
- (vii) Financial statement, indicating the broad details of all the running account payments received up to date, such as gross value of work done, advances taken, recoveries effected, amounts withheld, net payments, details of cheque payments received, etc.
- (viii) A statement showing the extra and substituted items submitted by the contractor, and the payment received against them, items pending for sanction/decision by the Department, broad details of the bank guarantees, indicating clearly their validity periods, broad details of the insurance policies taken by the contractor, if any, the advances received and adjusted from the department, etc.
- (ix) Progress photographs, in colour, of the various items/components of the work done up to date, to indicate visually the actual progress of the work.
- (x) Quality assurance and quality control tests conducted during the month, with the results thereof.

24. **PROGRESS REPORT**

The progress report submitted by the contractor has to be checked and certified by the Junior Engineer or Assistant Engineer, and has to be reviewed by the Executive Engineer and the Superintending Engineer, over their dated signatures.

A. Physical.

Name of Item	Quantity as per Agreement	Quantity extended during the month	Total up to date quantity executed	Anticipated balance quantity

B. Financial

Total Tendered amount	Work done during the month	Total amount of work done up to Date	Anticipated amount of balance work

25. The contractor has to submit the progress report to the Sub division office in quadruplicate by 10th day of every month as per the above proforma along with photographs of the work done during that month. The contractor shall be charged at Rs. 2500/- (Rupees Two thousand five hundred only) in the event of non-receipt of monthly progress report on due date (i.e., on 10th day of every month) to the sub division office in the manner prescribed above. In case 10th day happens to be a closed holiday then the progress report will be submitted on the next working day.